

Rebuild Pump from counter-clockwise (CCW) to clockwise (CW) Rotation

1. Remove the hub from the driver gear by removing the keyway set screw.
2. Remove the packing ring screws, the follower plates and the Teflon packing material from both sides of the driver gear – it may be possible to loosen the packing rings without removal of the packing and the gear will slide in and out of the assembly without binding up in the packing – if the gear binds up in the packing remove it completely and re-install the rings and packing during re-assembly.
3. Remove the side plate screws, the side plate and the bearings as shown in image #2 below. **NOTE: MAKE SURE TO NOTE THE ORIENTATION OF THE PARTS WHEN REMOVING FOR THEY MUST BE INSERTED THE SAME EXACT WAY AFTER THE DRIVER GEAR IS ROTATED.**
4. Rotate the driver gear as shown in image #3 below.
5. Insert the bearing the exact same way as they came out and do not forget the bearing dowel pin in between them. The dowel pin keeps them from rotating.
6. Insert the side plate and screws (torque to specifications in P.S.I. manual). Make sure that the “V” groove on the side plate lines up with the lube return port on the housing (shown below). This should be the case if the side plate is placed back on the exact same way that it came off.
7. Insert the packing material, the follower plates and the packing ring screws.
8. Mount the hub to the driver gear with the keyway set screw.

Image #1 – Pump Assembly (CCW Rotation) – Flow Inlet Shown

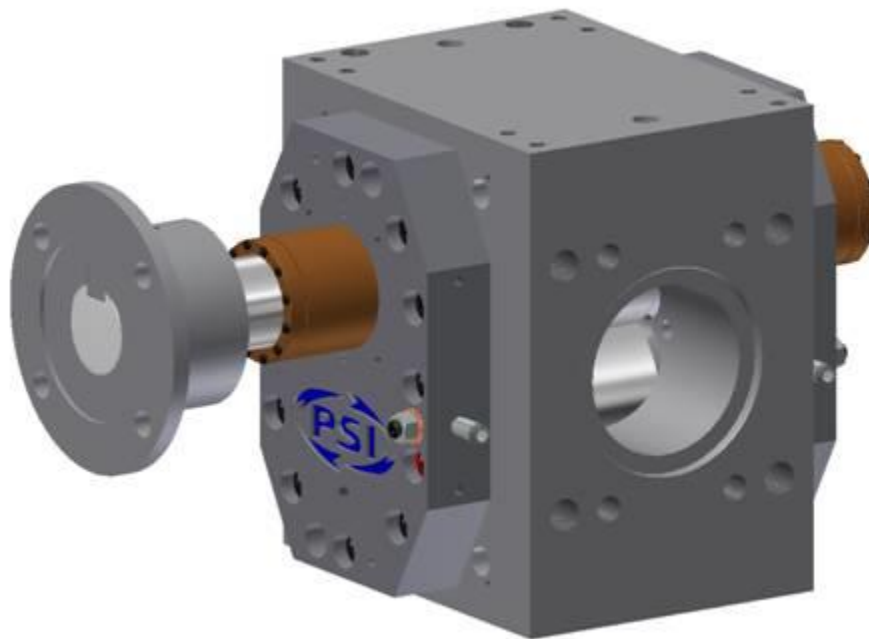

Department: Engineering	SOP No. ENG-0411-016	Revision No. 1
Prepared By:	Approved By:	Approval Date:
Effective Date: 04/26/2011	No. of Attachment: 0	Page #: 1 of 3

Image #2 – Pump Disassembly - Flow Inlet Shown

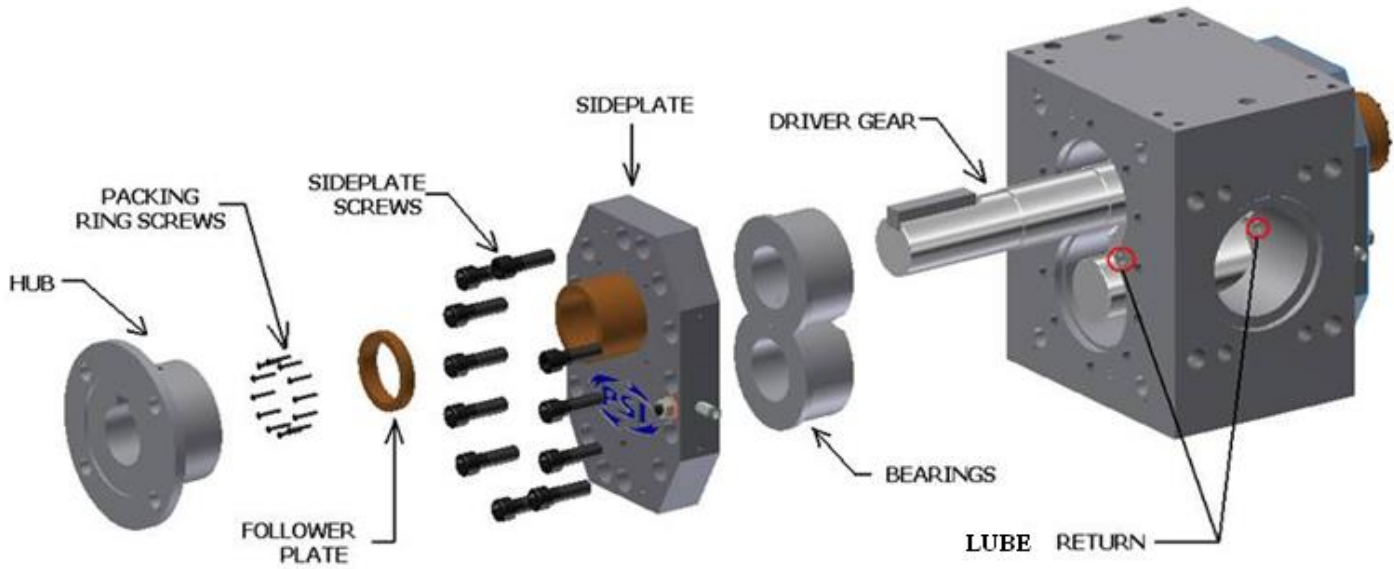
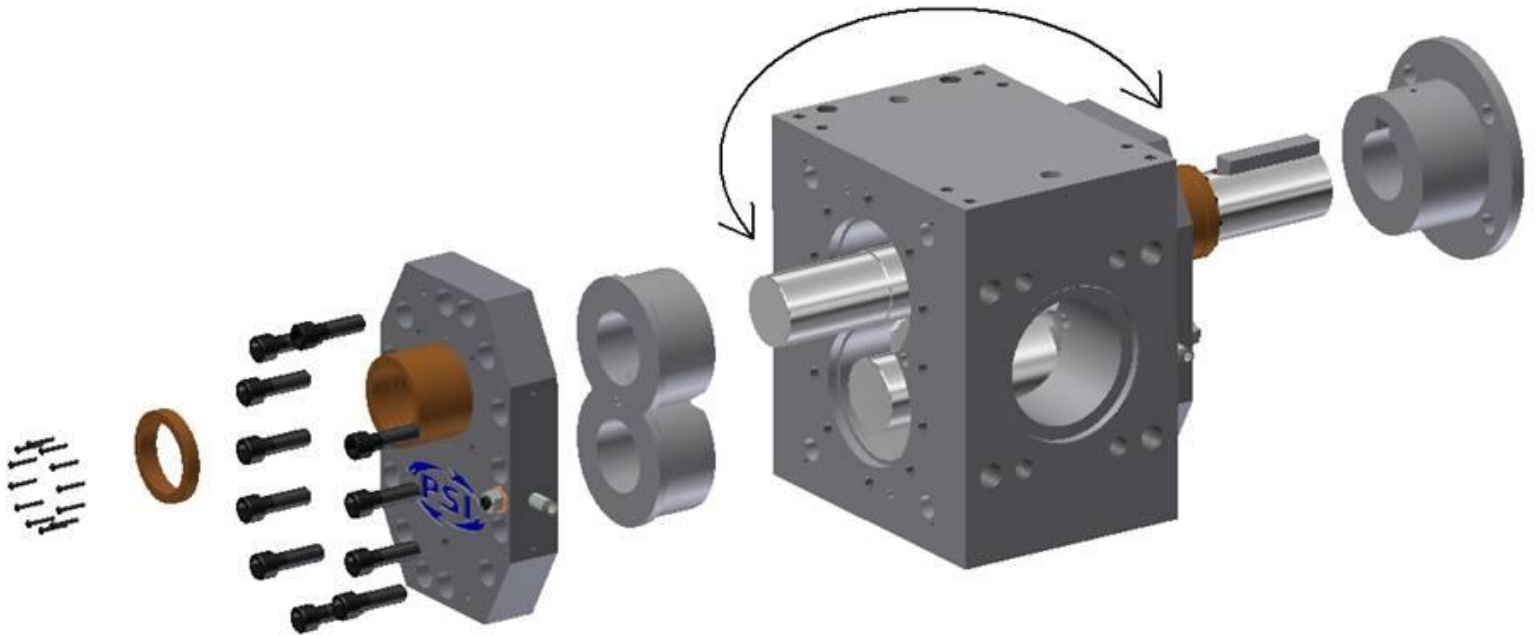
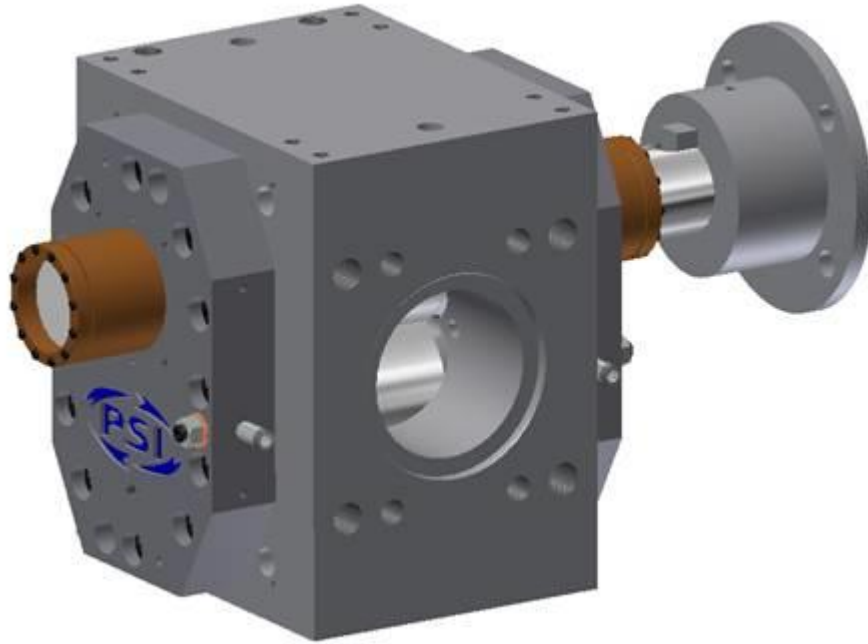

Image #3 – Rotate Driver Gear - Flow Inlet Shown



Department: Engineering	SOP No. ENG-0411-016	Revision No. 1
Prepared By:	Approved By:	Approval Date:
Effective Date: 04/26/2011	No. of Attachment: 0	Page #: 2 of 3

Image #4 – Pump Assembly (CW Rotation) - Flow Inlet Shown



Department: Engineering	SOP No. ENG-0411-016	Revision No. 1
Prepared By:	Approved By:	Approval Date:
Effective Date: 04/26/2011	No. of Attachment: 0	Page #: 3 of 3