

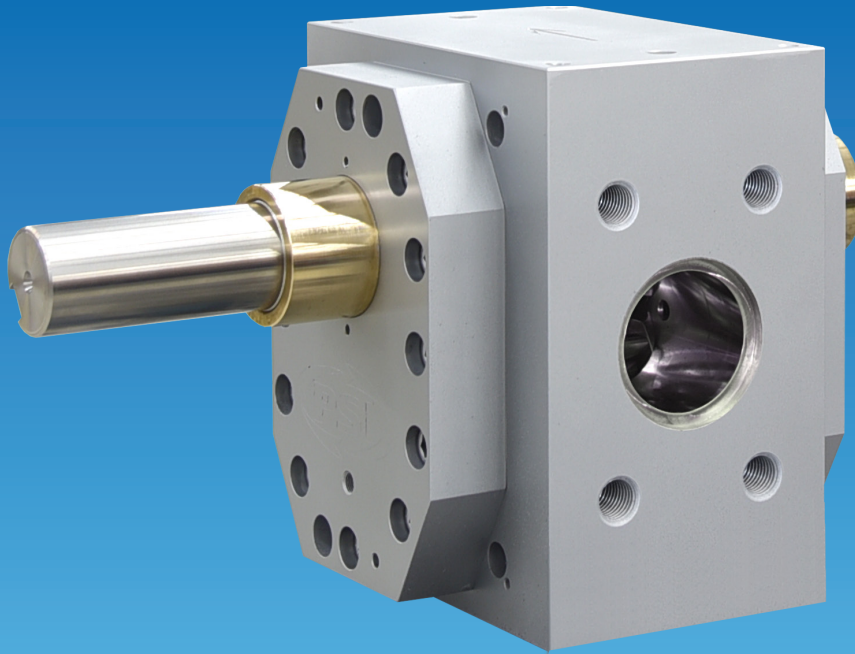

*Get More from Your Process*



## High Pressure Gear Pump (HGP)

PSI High Pressure Gear Pumps (HGP) feature a long-life, heavy-duty gear design that takes on the tough demands of high-torque polymer extrusion applications. Whether working with restrictive dies, highly viscous polymers, or rubber materials, the HGP delivers consistent performance where standard gear pump designs wear out or fail. These highly efficient positive displacement pumps take on the pressure building function to deliver a precise linear volume of output. This effectively takes the load off the extruder, reducing extruder amp draw and extending component life while delivering steady die pressure and uniform product gauge. The art is in the profile. PSI High Pressure Gear pumps offer high load gear shafts and an optimized gear tooth profile specially engineered to support high torsional loads through the long service life of the pump.

### Features

- Long-life through-hardened tool steel gears
- Non-square gear profile handles higher torque applications
- Bronze anti-galling Visco seals
- 30%-50% more seal area than any other competitor
- Up to 99+% efficient
- Pressure and temperature instrument ports
- Compact, low-profile design
- Drop-in replacements for most competitors' gear pumps

# High Pressure Gear Pump (HGP)

## Options

- Application specific materials of construction
- Application specific clearances
- Seal cooling
- High temperature to 750°F [454°C]
- Delta pressures to 7,500 psi [517 bar]
- Wear resistant materials and coatings
- Dual drive
- Internal fluid heat/cool
- Flush/bleed ports
- Pump or cart mounted J-box
- Synchronized haul-off control (integrated in PSI supplied PLC gear pump controller)

## Accessories

- Support cart
- Torque-limiting couplers
- Variable frequency drives
- Pressure instruments
- Adaptors
- Motor encoders
- PLC controls

## Technical

| Specifications                    | Standard                  |
|-----------------------------------|---------------------------|
| Throughput rate (pph) [kg/h]      | 2.7 - 9,750 [1.2 - 4,423] |
| Displacement (cc/rev)             | 4.03 - 1,477              |
| Temperature (°F) [°C]             | Up to 650 [343]           |
| Max oper. pressure (PSI) [bar]    | max. 10,000 [980]         |
| Differential pressure (PSI) [bar] | max. 7,500 [517]*         |
| Heating                           | Electric/Fluid            |

\*Material dependent – consult factory

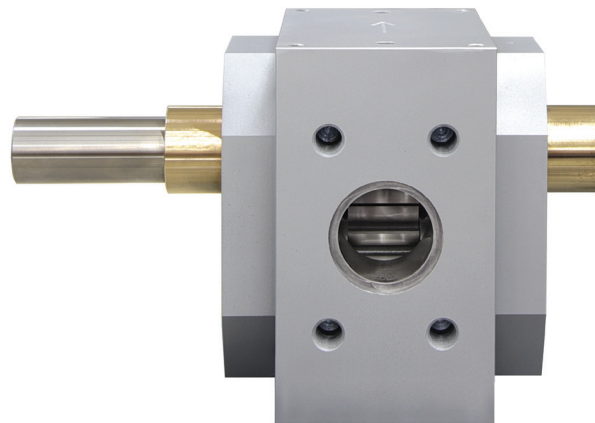

**Gear Comparison**

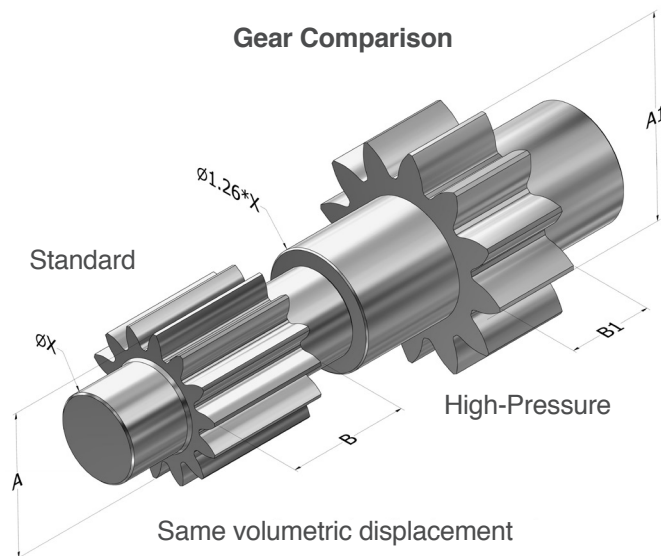
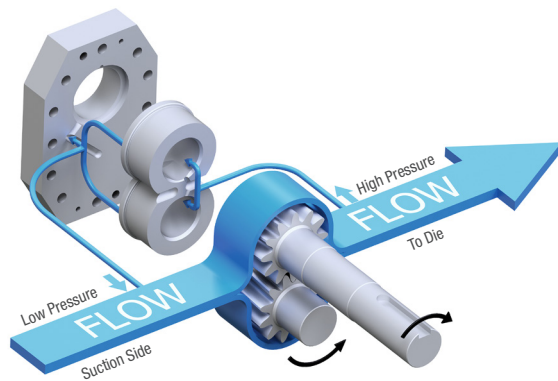

**Main Office:**  
PSI-Polymer Systems, Inc.  
1703 Pineview Street SE  
Conover, NC 28613  
United States

**Contact Us:**  
[www.psi-polymer.com](http://www.psi-polymer.com)  
[sales@psi-polymer.com](mailto:sales@psi-polymer.com)  
[service@psi-polymer.com](mailto:service@psi-polymer.com)  
Ph: USA 1.828.468.2600

**European Sales Office:**  
PSI-Polymer Systems Europe, GmbH  
Friedrich-Ebert-Str. 11  
DE 74177 Bad Friedrichshall, Germany  
HTS code: 8477900020

